

January, 2002

## Three Phase Triplex Overhead Distribution Transformer

The ABB Triplex overhead distribution transformer can be used to serve three phase applications through 225 kVA. Triplex designs consist of three separate single-phase core-coil assemblies in one tank.

Triplex overhead distribution transformers are often used to serve large motor loads where the motors are frequently started. Oil field pumping loads and some irrigation pumping loads should use only triplex designs. Also, the Triplex transformer has international applications where Dy 5 and Dy 11 phase displacement are required.

### Ratings

- 30-225 kVA
- 65°C rise
- 60 Hertz standard, 50 Hertz optional
- High Voltages: 13800 and below
- Low Voltages: 208Y/120, 240 x 480, and 480Y/277
- Transformer BIL Ratings

Transformer Primary	Transformer BIL
2400	60 kV
4160	60 kV
7200	75 kV
8320	75 kV
12000	95 kV
12470	95 kV
13200	95 kV
13800	95 kV

### Advantages

- Easier, cleaner installations are provided by three phase overhead transformers compared to three single-phase units.
- Reduced installation costs, lower operating costs, safer operation, minimized service disruptions, and



- increased transformer life provided by an optional CSP protection package.
- The capability to serve large motor loads requiring frequent motor starting is provided by triplex designs.
- The same design, manufacturing and performance advantages that are provided on ABB single phase overhead distribution transformers are incorporated into the triplex design.

### Features

- 1) Wound core with step-lap joints for increased efficiency and lower noise levels.

- 2) Progressively wound coils with adhesive resins on insulating paper or conductors for increased short-circuit strength, efficiency and thermal strength.
- 3) CSP protection package available as an option for increased protection against surge currents, short circuits and overloads:
  - Primary protective links
  - Surge arresters
  - Secondary circuit breaker
  - Secondary breaker operating handle with emergency overload reset and overload signal light.
- 4) Three point core-coil bracing for increased mechanical strength.
- 5) Self-venting and resealing cover that eliminates the need for an auxiliary pressure relief device and offers increased safety through higher tank withstand.
- 6) The paint finish process applies a durable, corrosion resistant finish to the product. The finish meets or exceeds all the performance requirements of ANSI C57.12.28. The multi-step process includes an epoxy primer uniformly applied by cationic electro-deposition and a urethane top coat.
- 7) Cover has 13 mils minimum of polyester coating providing 15 kV dielectric insulation of tank ground parts from live parts and increasing resistance to corrosion. The cover is sloped 15° preventing water from collecting, thereby reducing the chances of corrosion and leaking.
- 8) Tank bottom rim is three layers thick for increased durability and resistance to shipping and handling damage.

**Standard Design Dimensions and Weights** (All weights and dimensions are approximate.)

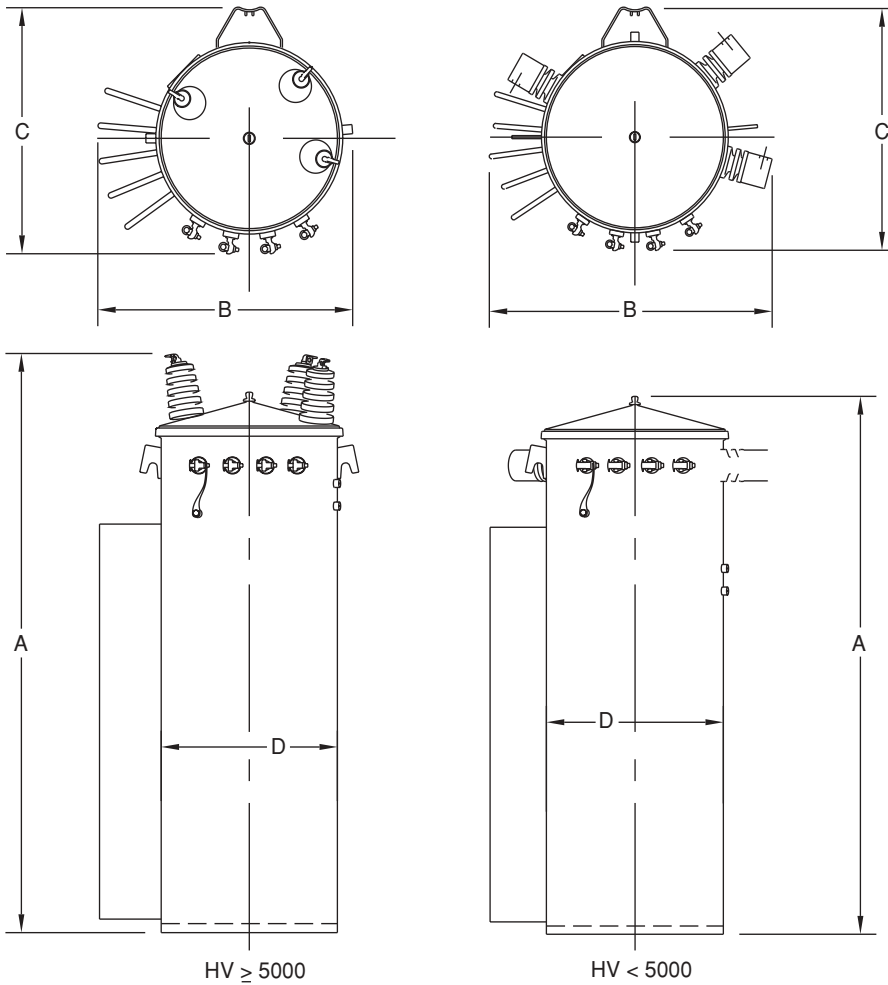

Overall weights and dimensions are given in pounds, inches or gallons and are approximate  
 A = Overall Height, B = Overall Width, C = Overall Depth, D = Tank Diameter, E = Hanger Spacing

**High Voltages 4160GY/2400, 7200GY/4160, 8320GY/4800**

KVA	A	B	C	D	E*	Wgt	Ship Wgt	OIL Qty
30	53	26	25	17.5	11.25	760	805	40
45	57	26	25	17.5	23.25	915	960	45
75	61	33	28	20	23.25	1120	1165	60
112.5	61	34	28	20	36	1540	1585	58
150	73	35	30	22	36	2455	2525	90
225	76	35	30	22	36	2650	2745	90

**High Voltages 12470GY/7200, 14400GY/8320**

KVA	A	B	C	D	E*	Wgt	Ship Wgt	OIL Qty
30	58	23	25	17.5	11.25	760	805	40
45	62	23	25	17.5	23.25	920	965	45
75	66	29	28	20	23.25	1310	1355	60
112.5	66	34	28	20	36	1540	1585	58
150	78	31	30	22	36	2470	2540	90
225	81	31	30	22	36	2650	2745	90

**High Voltages 20780GY/12000, 21590GY/12470, 22860/GY13200, 23900GY/13800**

KVA	A	B	C	D	E*	Wgt	Ship Wgt	OIL Qty
30	65	23	25	17.5	11.25	940	985	45
45	68	26	28	20	23.25	1290	1340	60
75	68	26	28	20	23.25	1340	1365	58
112.5	68	34	28	20	36	1540	1585	58
150	80	31	30	22	36	2470	2540	90
225	83	31	30	22	36	2650	2745	90

\*E is the distance between the hanger brackets.